

# K12 Robotics2025-2026

## 1<sup>st</sup> Qualifier

### Grades: 10-12



# Table of Contents

|   |    |
|---|----|
| General Rules .....                                     | 2  |
| How to score in a team competition? .....               | 4  |
| Robot Missions.....                                     | 4  |
| Score.....  | 4  |
| Scoring Interpretation .....                            | 4  |
| Important Information .....                             | 6  |
| Robot Ports.....  | 6  |
| How to create your video?.....                          | 7  |
| <b>How to share your video to us? (All Teams)</b> ..... | 10 |

## General Rules

1. All teams must consist of 1 to 3 competitors.
2. **The participants must be from the category age group or younger. The competitor must never be older than the category age group.**
3. **It is not allowed to make changes in the environment before, after and during the simulation.  
It is not allowed to import your own robot.**
4. When the simulation starts, the competitor can only use the camera's tools and the scoreboard button.
5. All the tasks need to be solved only by using the code created by the team for the robot.
6. In case, the Judging Team suspects of the score/time of any competitor, they can request a video or a conference from the team, to prove how their result was gotten according to the rules and requirements allowed. In case the competitor doesn't accept the video, conference or doesn't prove how the score/time was gotten, the result will be deleted from the ranking.
7. **In all the categories, ALL THE TEAMS must send a video (one per team) of their robot solving the challenge.**
8. **In the video, the robot's points must be equal and the time must be equal or within  $\pm 1$  seconds of the best round obtained by the participant and is displayed in the leaderboard.**

|   |  |            |   |     |           |
|---|--|------------|---|-----|-----------|
| 3 | <br><b>Team</b><br>CDMX, MX | 2021-07-13 | 3 | 100 | 02:23.074 |
|   | <b>Team member 3</b><br>CDMX, MX   | -          | - | 100 | 02:23.015 |
|   | <b>Team member 2</b><br>CDMX, MX   | -          | - | 100 | 02:23.271 |
|   | <b>Team member 1</b><br>CDMX, MX   | -          | - | 100 | 02:22.936 |
|   | <b>Team member 2</b><br>CDMX, MX   | -          | - | 100 | 02:26.426 |
|   | <b>Team member 2</b><br>CDMX, MX   | -          | - | 100 | 02:27.186 |
|   | <b>Team member 3</b><br>CDMX, MX   | -          | - | 75  | 02:51.019 |

**In the example the best round was from “Team member 1”, so the robot in the video must have the same score (100) and in the time be equal or  $\pm$  1 seconds (21.936-23.936 seconds).**

In case of any unforeseen circumstances in which the rules have to be altered, the judges will have the final say in the results.

The judges have the utmost authority to amend the rules and regulations.

The judges have the utmost authority to disqualify a result if:

1. Participants pause and resume the simulator in between the code.
2. Participants create any other situations which judges deem unacceptable

# How to score in a team competition?

To determine the team's score, the system will take the best result of each team member to determine an average score and an average time.

In this video you will find a better explanation of how to create a team and how to submit results.

<https://youtu.be/lh2l4UfuFpk>

- Video: [How to create a Solo Team](#)

## Robot Missions

### Bathroom:

The robot must move the red bulb to the red zone.

The robot must move the white bulb to the yellow zone.

### Living Room:

The robot must move the red bulb to the red zone.

The robot must move the white bulb to the yellow zone.

The mission is complete when the robot parks into the final area and the chassis of the robot is entirely (top-view) within the area.

For more understanding you can see the next sample video:

[https://youtu.be/Gh\\_ZEFEO9Fw](https://youtu.be/Gh_ZEFEO9Fw)

## Score

| K12 Robotics Competition 2025-2026 10 to 12 Grade 1st. Qualifier                        | Each | Total      |
|---|------|------------|
| <b>Bathroom</b>   |      |            |
| Red Bulb delivered completely in the red zone.  | 20   | 20         |
| White Bulb delivered completely in the yellow zone.                                     | 20   | 20         |
| <b>Living Room</b>  |      |            |
| Red Bulb delivered completely in the red zone.  | 20   | 20         |
| White Bulb delivered completely in the yellow zone.                                     | 20   | 20         |
| <b>Park the robot</b>   |      |            |
| Robot stops on Finish Area and simulation stops.<br>(only if other points are assigned) | 20   | 20         |
| <b>Maximum Score</b>  |      | <b>100</b> |

# Scoring Interpretation



**Bathroom**

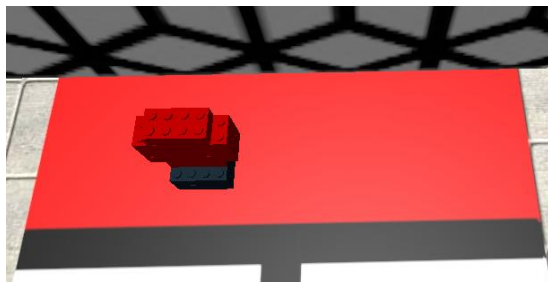

Red bulb delivered completely in the red zone. It is not important if the bulb is standing or lying but it is important the object to stay completely inside the zone.

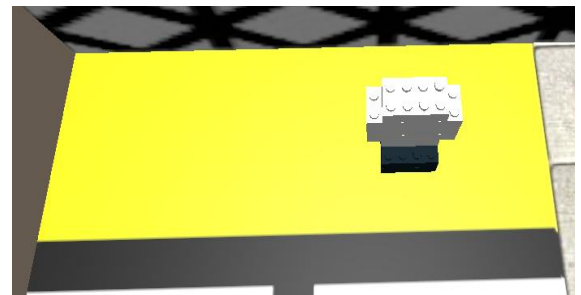

Yellow bulb delivered completely in the red zone. It is not important if the bulb is standing or lying but it is important the object to stay completely inside the zone.

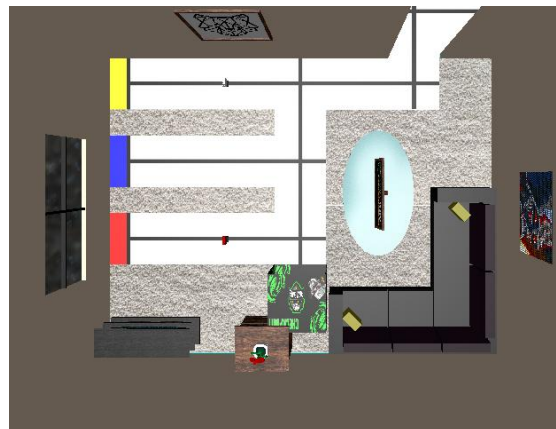

**Living Room**

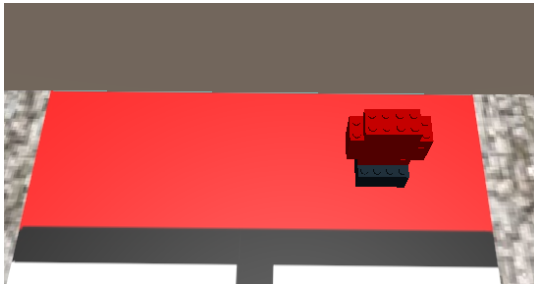

Red bulb delivered completely in the red zone. It is not important if the bulb is standing or lying but it is important the object to stay completely inside the zone.

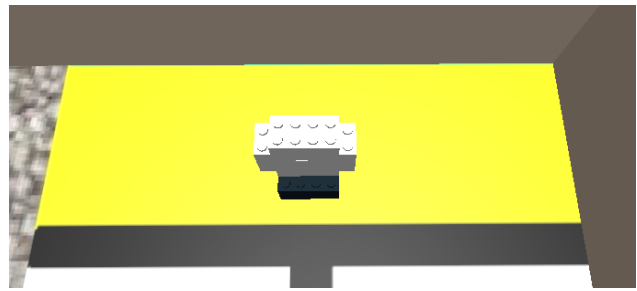

Yellow bulb delivered completely in the red zone. It is not important if the bulb is standing or lying but it is important the object to stay completely inside the zone.

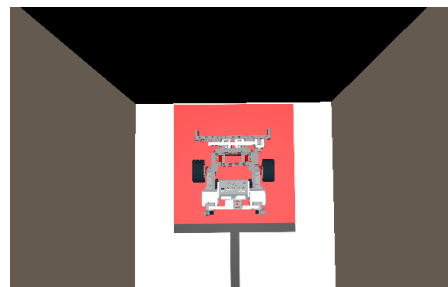

Robot stops on Finish Area and simulation stops. (only if other points are assigned)

## Important Information

Start time to submit results: February 27 at 4:00 pm ET.

End Time to submit results: March 6 at 11:00 pm ET.

Closing Ceremony: March 9 at 4:00 pm ET.

## Robot Ports

**\*Remember, it is not allowed to import a new robot.**

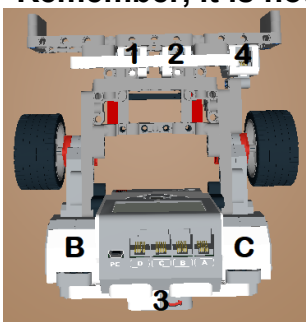

# How to create your video?

You need to record computer screen using Windows 10 Function, QuickTime player, OBS or other option to record screen.

Screen record Windows 10

[https://youtu.be/mVJsm\\_000c0](https://youtu.be/mVJsm_000c0)

Screen record Mac

<https://youtu.be/s9xnsj6ditM>

Screen record OBS

<https://youtu.be/QKmrDUJFRkM>

Install OBS:

<https://obsproject.com/>

The participant must upload the video on YouTube, Vimeo, Google Drive, etc.

How to upload a video on YouTube?

<https://youtu.be/4RZ3FooBKYE>

If you upload your video on YouTube, you have to publish it as Public or Unlisted.

## **Record Details**

On the video, the participant has to show the robot solving all the challenge. If the video starts after the robot begins solving the challenge or cuts the video before the robot finishes the task, the video will not be valid.

-Participants must place their Team name in the virtual brick or in the name of their code.



-The robot and the scoreboard must be visible all the time.

-On the video the participant must use “Top Camera” and “Tether” tracking type.

### Top Camera and Tether tracking type

1) Need to open Advanced Mode.

To access "Advanced Mode", all you have to do is press "F12" on your keyboard.

Could be:

-F12

-Ctrl+F12

-Fn+F12

-Alt+F12

-Cmd+F12

Simple Mode



Advanced Mode



2) Move the Virtual EV3 Brick.

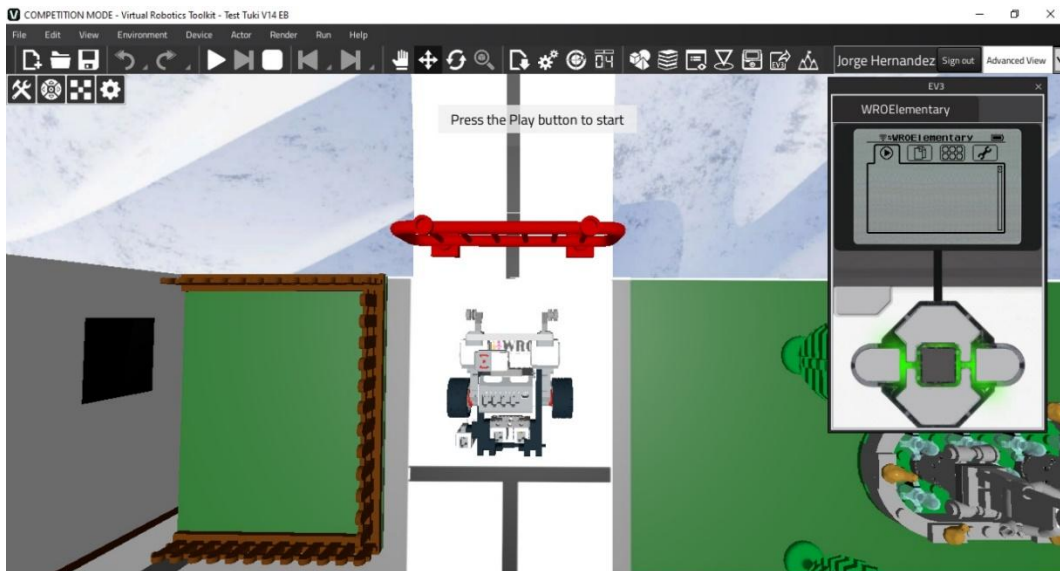

3) Select the robot and use Top Camera.

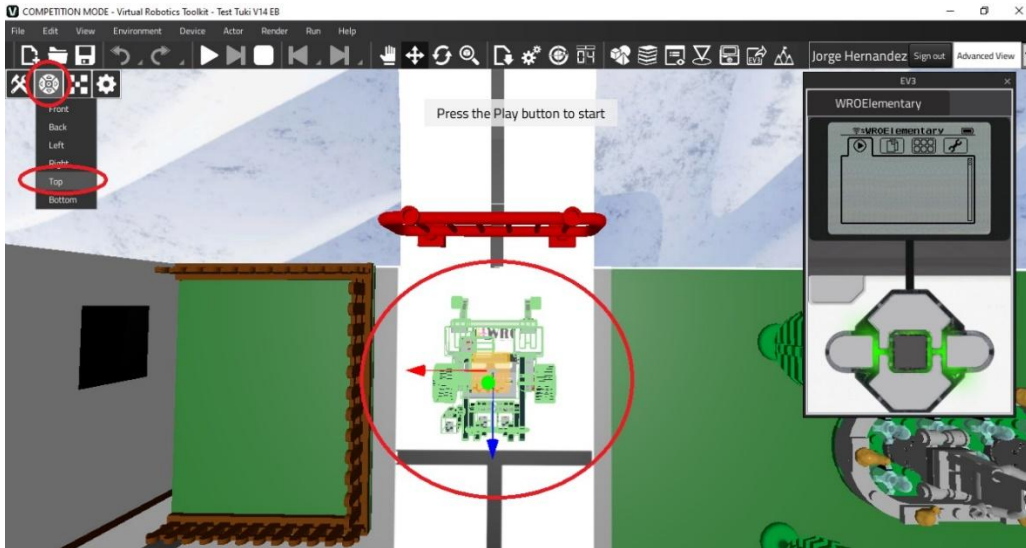

4) Use “Tether” Tracking type.

The robot must be selected and then click on “Set Target object”.  
Change Tracking type to “Tether”.

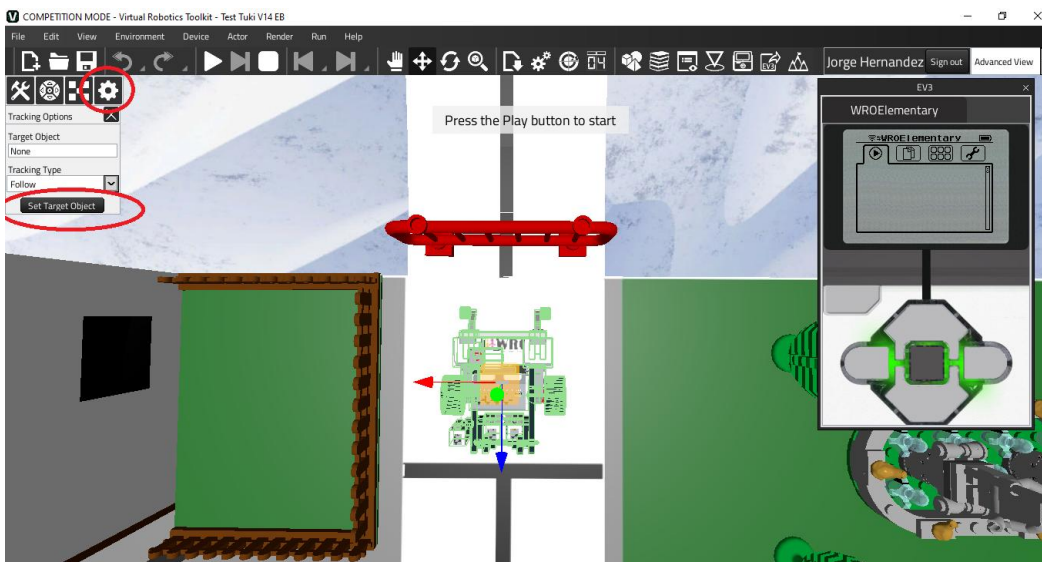

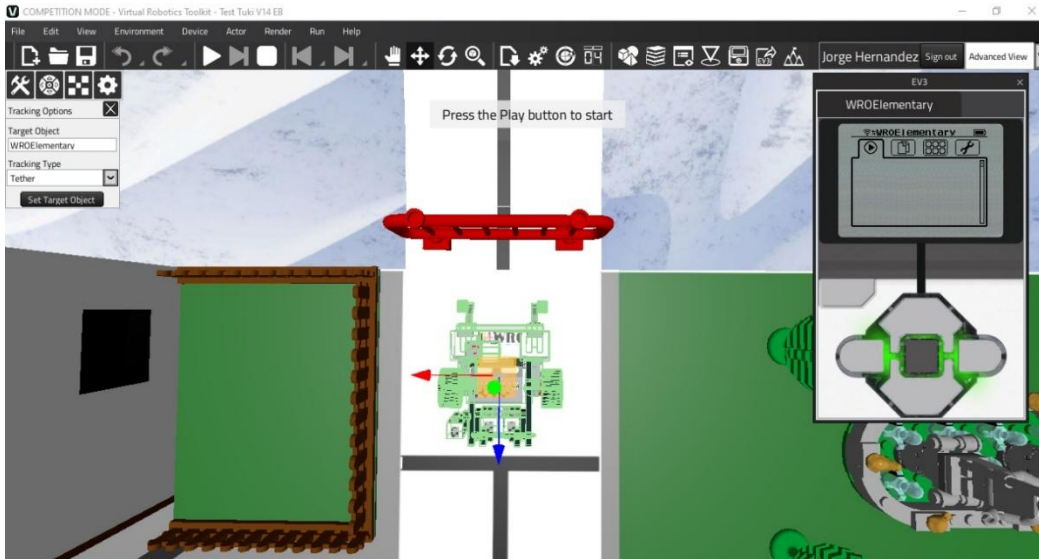

Top Camera & Tether Tracking type tutorial:

<https://youtu.be/hNvJNMnV9dM>

## How to share your video to us? (All Teams)

The participant can share a video of your robot solution filling the form. Please be aware of your email.

<https://forms.gle/7qvJp6hmPtboLrgq8>

\*Please be careful, the form is specific for this category