



AZERBAIJAN

World Robot Olympiad 2021

Regular Category

Elementary Advanced Level

Energy at Home

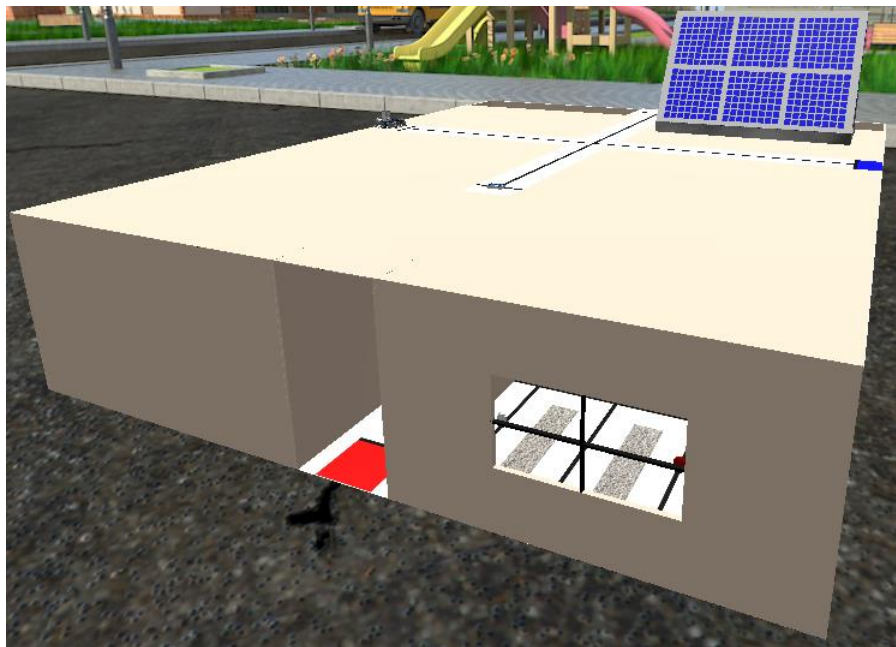

July 14 Version

Table of Contents

General Rules	2
Format of the competition.....	4
How to score in a team competition?.....	4
Robot Missions.....	4
Score.....	5
Scoring Interpretation	6
Checkpoints.....	9
Important Information	9
Robot Ports.....	10
How to create your video?.....	12
How to share your Top 5 video to us?	15

General Rules

1. All teams must consist of 2 or 3 competitors.
2. The team must be from the category age group or younger. The competitor must never be older than the category age group.
3. **It is not allowed to make changes in the environment before, after and during the simulation.**
In Advanced level is allowed to import your own robot.
4. **The only change allowed is to import a robot and rotate it within the Start Zone before the simulation starts. This robot can only be a maximum of 30 cm. in width, height and length.**
5. When the simulation starts, the competitor can only use the camera's tools and the scoreboard button.
6. All the tasks need to be solved only by using the code created by the participant for the robot.
7. **In case, the Judging Team suspects of the score/time of any competitor, they can request a video or a conference from the participant, to prove how their result was gotten according to the rules and requirements allowed. In case the competitor doesn't accept the video, conference or doesn't prove how the score/time was gotten, the result will be deleted from the ranking.**

8. **In all the categories, the top 5 must send a video (one per team) of their robot solving the challenge.**
9. **In the video, the robot's points must be equal and the time must be equal or within ± 1 seconds of the best round obtained by the team members and is displayed in the leaderboard.**

3	 Team CDMX, MX	2021-07-13	3	100	02:23.074
	Team member 3 CDMX, MX	-	-	100	02:23.015
	Team member 2 CDMX, MX	-	-	100	02:23.271
	Team member 1 CDMX, MX	-	-	100	02:22.936
	Team member 2 CDMX, MX	-	-	100	02:26.426
	Team member 2 CDMX, MX	-	-	100	02:27.186
	Team member 3 CDMX, MX	-	-	75	02:51.019

In the example the best round was from “Team member 1”, so the robot in the video must have the same score (100) and in the time be equal or ± 1 seconds (21.936-23.936 seconds).

In case of any unforeseen circumstances in which the rules have to be altered, the judges will have the final say in the results.

The judges have the utmost authority to amend the rules and regulations.

The judges have the utmost authority to disqualify a result if:

1. Participants pause and resume the simulator in between the code.
2. Participants create any other situations which judges deem unacceptable

Format of the competition

There will be three newly designed VRT Mat Challenges.

On each WRO Age Group, there will be two challenges with the same Mat. One will be a Beginners Challenge and another will be an Advanced Challenge. The Advanced Challenge will be more complex and the teams are allowed to import their own robot.

You can only participate in one of the two challenges per Age Group. That means that you must choose between Beginners and the Advanced Challenge

You can only be part of one team.

	Elementary Category Beginners Level	Junior Category Beginners Level	Senior Category Beginners Level	Elementary Category Advanced Level	Junior Category Advanced Level	Senior Category Advanced Level
Age	Max. 12 years	13-15 years	16-19 years	Max. 12 years	13-15 years	16-19 years
Team Size	2 or 3 competitors per team					
Official Simulator	Virtual Robotics Toolkit					
Robot	It's not allowed to import your own robot.			Is allowed to import your own robot.		
Software	Open to any control software that can connect to Virtual Robotic Toolkit					

How to score in a team competition?

To determine the team's score, the system will take the best result of each team member to determine an average score and an average time.

In this video you will find a better explanation of how to create a team and how to submit results.

<https://youtu.be/lh2l4UfuFpk>

Robot Missions

Roof:

The robot must move the solar cell to the blue zone.

Bathroom:

The robot must move the red bulb to the red zone.

The robot must move the white bulb to the yellow zone.

Bedroom:

The robot must move the red bulb to the red zone.

The robot must move the white bulb to the yellow zone.

Kitchen:

The robot must move the red bulb to the red zone.

The robot must move the white bulb to the yellow zone.

Living Room:

The robot must move the red bulb to the red zone.

The robot must move the white bulb to the yellow zone.

The mission is complete when the robot parks into the final area and the chassis of the robot is entirely (top-view) within the area.

For more understanding you can see the next sample video:

<https://youtu.be/THxLV3K3f7M>

Score

Elementary Advanced Category Energy at Home	Each	Total
Roof		
Solar cell delivered completely in the blue zone.	10	10
Bathroom		
Red Bulb delivered completely in the red zone.	10	10
White Bulb delivered completely in the yellow zone.	10	10
Bedroom		
Red Bulb delivered completely in the red zone.	10	10
White Bulb delivered completely in the yellow zone.	10	10
Kitchen		
Red Bulb delivered completely in the red zone.	10	10
White Bulb delivered completely in the yellow zone.	10	10
Living Room		
Red Bulb delivered completely in the red zone.	10	10
White Bulb delivered completely in the yellow zone.	10	10
Park the robot		
Robot stops on Finish Area and simulation stops. (only if other points are assigned)	10	10
Maximum Score		100

Scoring Interpretation

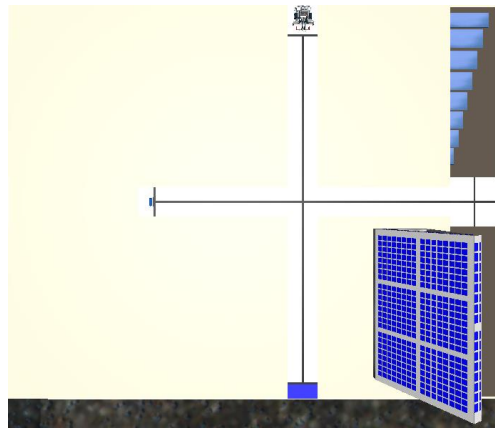

Roof

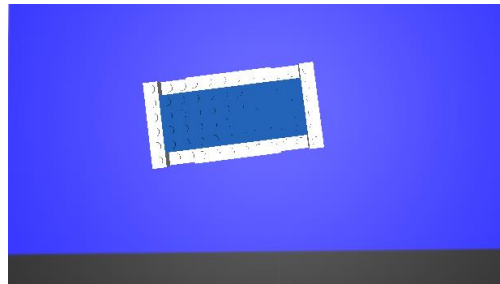

Solar Cell delivered completely in the blue zone. It is not important if the solar cell is standing or lying but it is important the object to stay completely inside the zone.



Bathroom

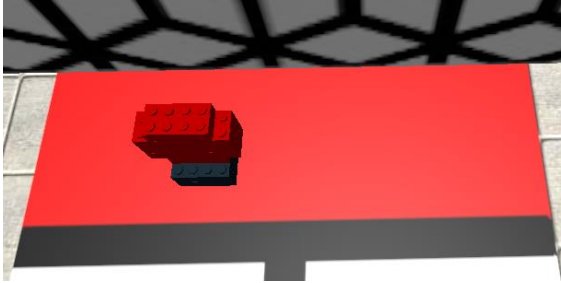

Red bulb delivered completely in the red zone. It is not important if the bulb is standing or lying but it is important the object to stay completely inside the zone.

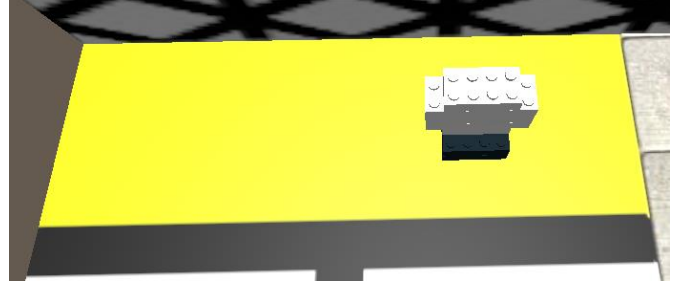

White bulb delivered completely in the red zone. It is not important if the bulb is standing or lying but it is important the object to stay completely inside the zone.



Bedroom



Red bulb delivered completely in the red zone. It is not important if the bulb is standing or lying but it is important the object to stay completely inside the zone.

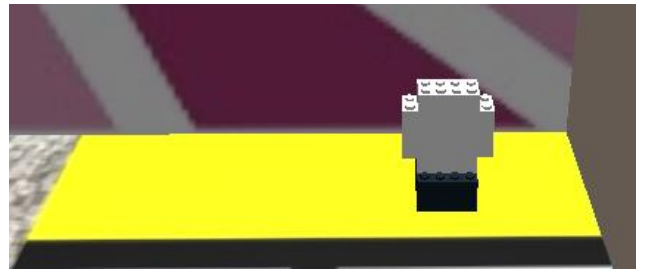

White bulb delivered completely in the red zone. It is not important if the bulb is standing or lying but it is important the object to stay completely inside the zone.

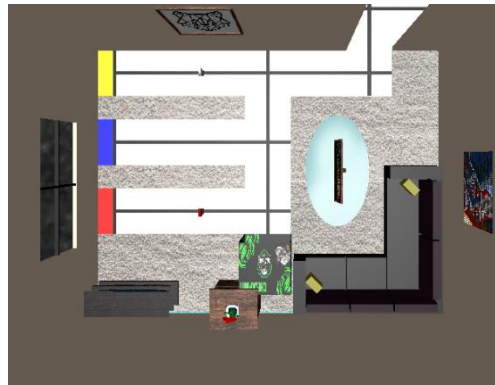

Living Room

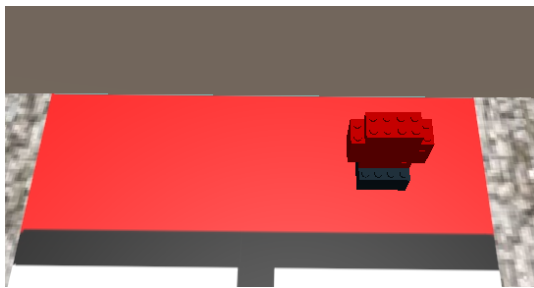

Red bulb delivered completely in the red zone. It is not important if the bulb is standing or lying but it is important the object to stay completely inside the zone.

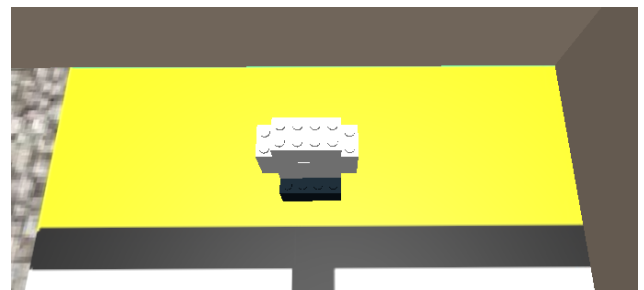

White bulb delivered completely in the red zone. It is not important if the bulb is standing or lying but it is important the object to stay completely inside the zone.



Kitchen



Red bulb delivered completely in the red zone. It is not important if the bulb is standing or lying but it is important the object to stay completely inside the zone.



White bulb delivered completely in the red zone. It is not important if the bulb is standing or lying but it is important the object to stay completely inside the zone.

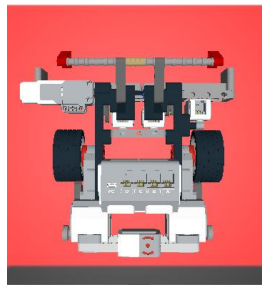

Robot stops on Finish Area and simulation stops. (only if other points are assigned)

Checkpoints



In the challenge you can find checkpoints, the robot can go inside them and the challenge will end allowing you to submit your result.

If the robot is inside the checkpoint, you will not get the point of the final zone.

Important Information

Details of specific tasks, the start time to submit result is July 24 00:00 GMT+4

The end time to **submit results** is **July 26 23:59 GMT+4**

The end time to **fill the form** is **July 27 1:00 GMT+4**

Closing Ceremony is **July 27**

If a top 5 teams doesn't fill the form they will not receive the special certificate and any prize.

Recommendation:

If you think your result will be on top 5 you can fill the form before **July 27 1:00 GMT+4**

Robot Ports



Advanced Level: *Remember, it is allowed import a new robot.

On this link you can find the robot on LEGO® Digital Designer or Studio 2.0

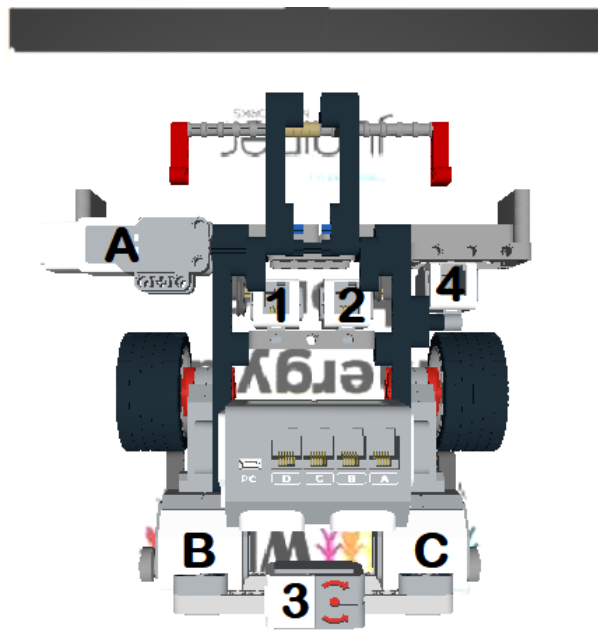
<https://drive.google.com/drive/folders/1FGF6u-0mGVTN56Q-2cg512I09thNmMdu?usp=sharing>





Tie Result

18	 Team 1 Sarawak, MY	2021-07-03	4	20	00:22.549
18	 Team 2 CDMX, MX	2021-07-13	5	20	00:22.549

If two or more teams have the same average result on the leaderboard, the judging team will review the next highest average results of the participants.

When the judging team finds out which team got better results, they will take out 0.001 seconds from the time on the leaderboard of the team winner team to tiebreaker the result.

On the example "Team 2" got a second better high score, it means we will take 0.001 seconds of the team average time result.

18	 Team 2 CDMX, MX	2021-07-13	5	20	00:22.548
19	 Team 1 Sarawak, MY	2021-07-03	4	20	00:22.549

If one of the teams only have 1 submitted average result the other team will be the winner of the tiebreaker.

Difference from the Real Time Result

Judging team detected less than 1% of the users have a PC issue where the time result that it submits takes out the decimal seconds.

Example:

Real time result: 00:55.230

Submitted time result: 00:55.000

If a team has any participant with this issue, the participant needs to fill a special form where they will share a video of the solution and we will exchange with the time displayed in the video.

-The video needs to have the same “Recording Details” as the “Top 5” video.

-The difference between the submitted time result and video time result only could be decimal seconds, it means that the minutes and seconds need to be exactly the same.

Example:

Submitted time result: 00:45.000

Video time result could be only between 00:45.001 and 00:45.999. If the video does not comply with the above rules or the participant does not fill out the form to send the video. The decimal seconds of the submitted time will be changed to "X.999".

Example:

Submitted time result: 00:37.000

New Submitted time result: 00:037.999

Difference from the Real Time Result Form:

<https://forms.gle/Eo4n2hU3bQ2h8VGe9>

How to create your video?

You need to record computer screen using Windows 10 Function, QuickTime player, OBS or other option to record screen.

Screen record Windows 10

https://youtu.be/mVJsm_000c0

Screen record Mac

<https://youtu.be/s9xnsj6ditM>

Screen record OBS

<https://youtu.be/QKmrDUJFRkM>

Install OBS:

<https://obsproject.com/>

The participant must upload the video on YouTube, Vimeo, Google Drive, etc.

How to upload a video on YouTube?

<https://youtu.be/4RZ3FooBKYE>

If you upload your video on YouTube, you have to publish it as Public or Unlisted.

Record Details

-On the video, the participant has to show the robot solving all the challenge. If the video starts after the robot begins solving the challenge or cuts the video before the robot finishes the task, the video will not be valid.

-Participants must place their Team name in the virtual brick or in the name of their code.



-The robot and the scoreboard must be visible all the time.

-On the video the participant must use "Top Camera" and "Tether" tracking type.

Top Camera and Tether tracking type

1) Need to open Advanced Mode.

To access "Advanced Mode", all you have to do is press "F12" on your keyboard.

Could be:

-F12

-Ctrl+F12

-Fn+F12

-Alt+F12

-Cmd+F12

Simple Mode



Advanced Mode



2) Move the Virtual EV3 Brick.

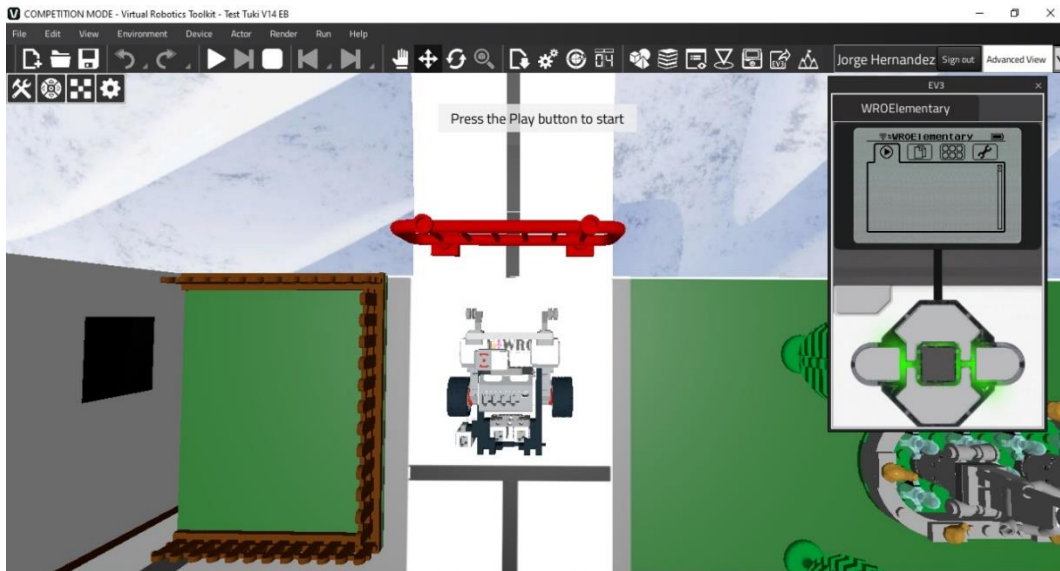

3) Select the robot and use Top Camera.

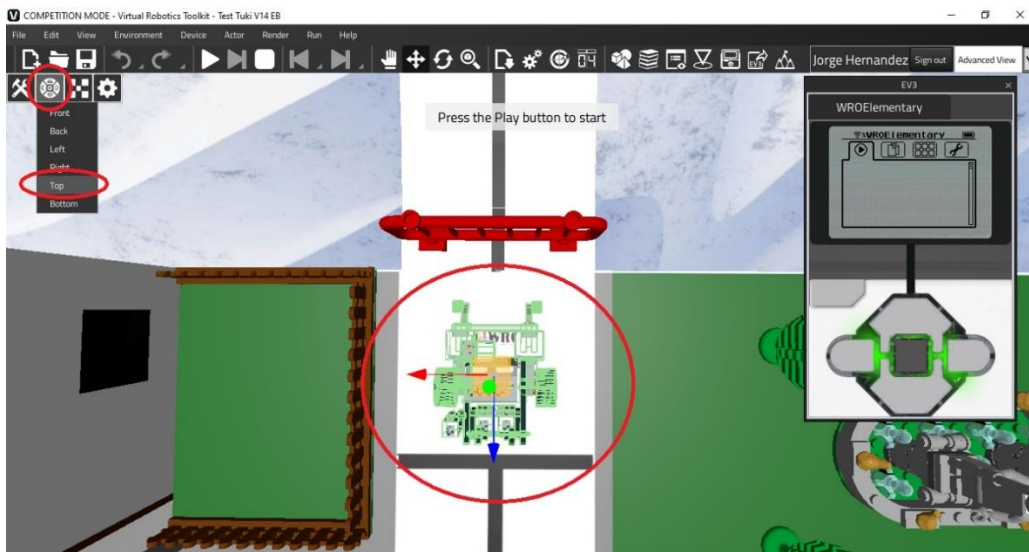

4) Use “Tether” Tracking type.

The robot must be selected and then click on “Set Target object”.
Change Tracking type to “Tether”.

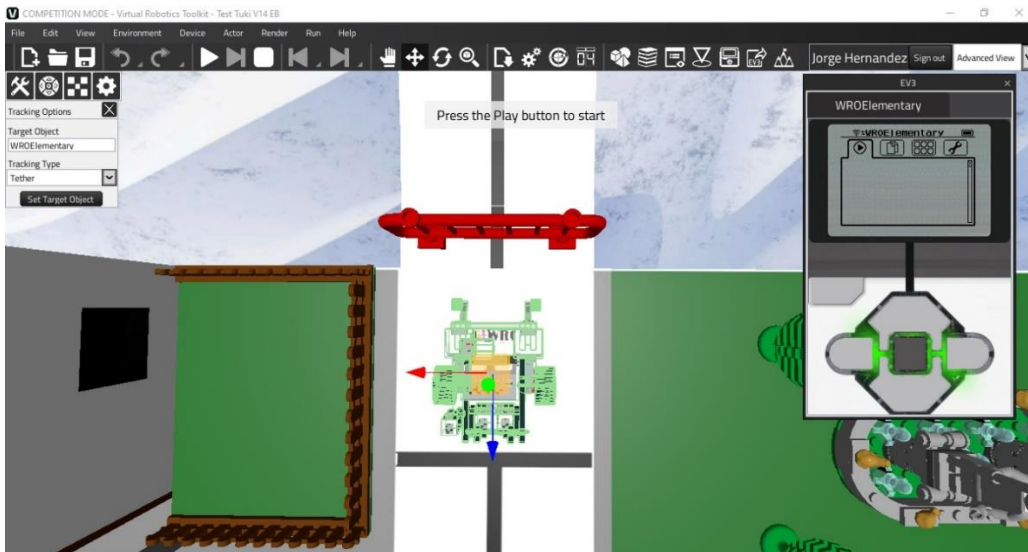
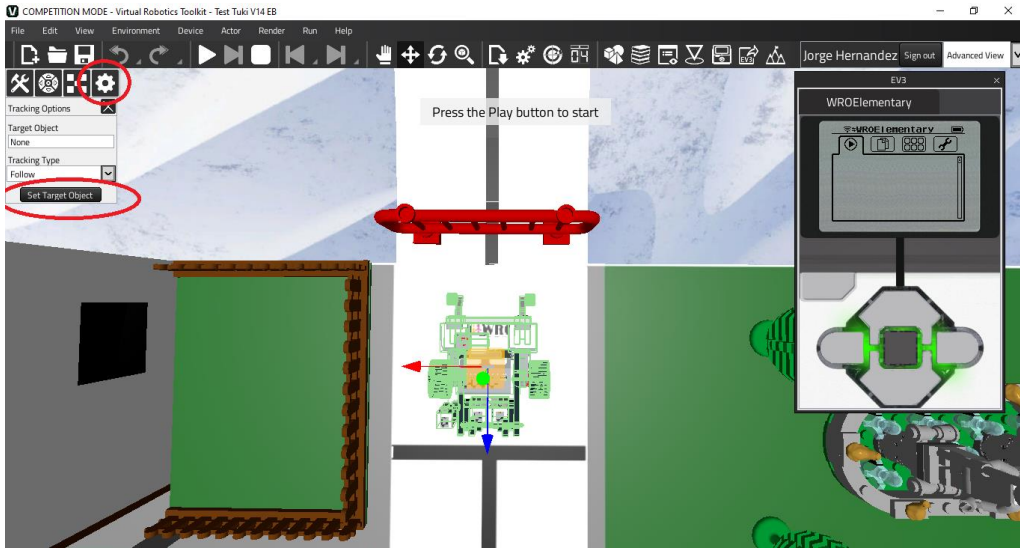

Top Camera & Tether Tracking type tutorial:

<https://youtu.be/hNvJNMnV9dM>

How to share your Top 5 video to us?

The participant needs to click on the link and fill the form.

Please be aware of your email, because in case there's a problem with your video or your results, we will contact you.

<https://forms.gle/tK3qMzTiLAPHncAL9>

*Please be careful, the form is specific for this category